

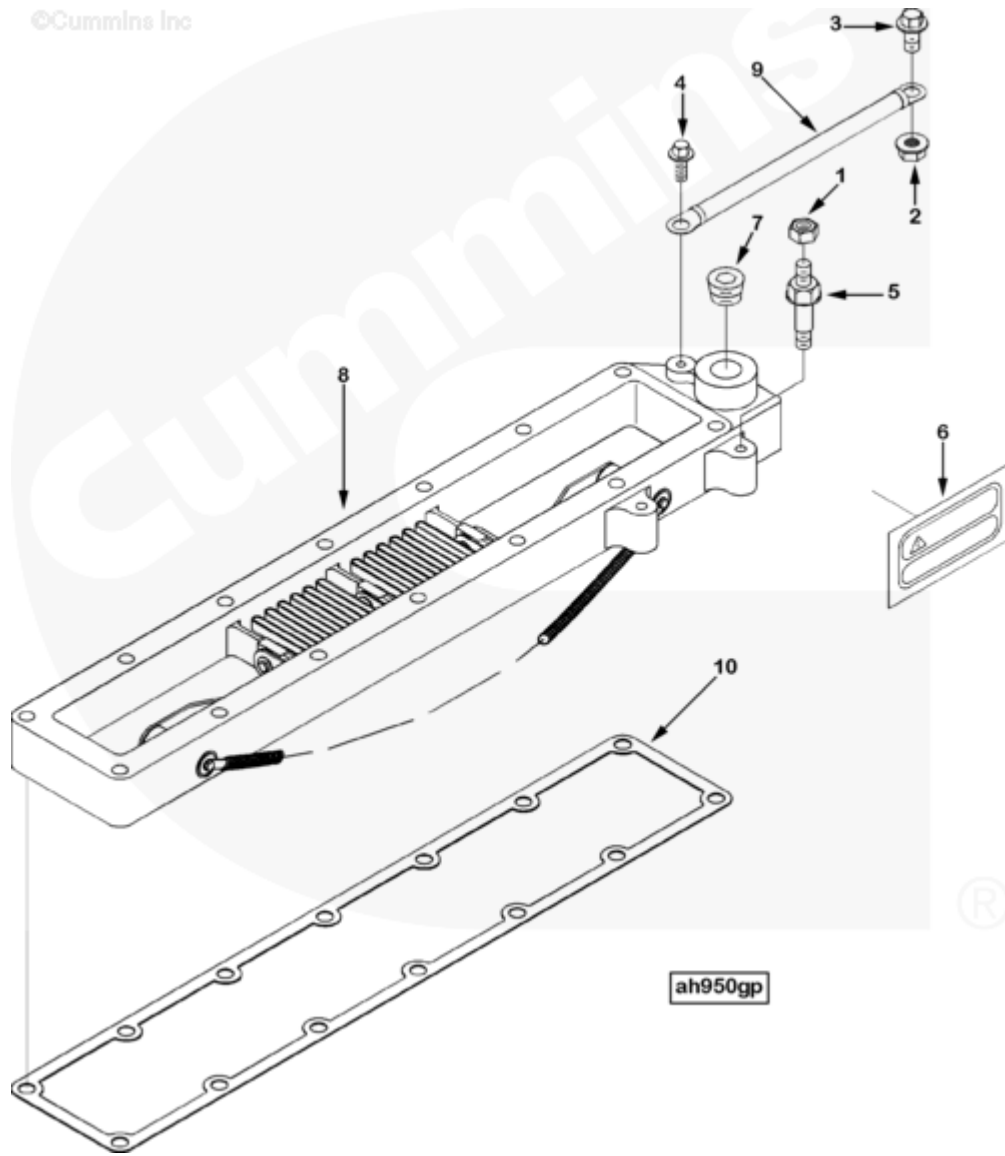

Parts Catalog - Option Detail

Electronic Parts Catalog - Option Detail				
Option	Group	Graphic	Film Card	Date
AH9051-01	10.02	ah950gp	T	07-FEB-97
Engines	4B3.9, 6A3.4, 6B5.9, B GAS INTERNATIONAL CM556, B4.5, B4.5 CM2350 B129B, B4.5 CM2350 B146C, B4.5 CM2350 B147B, B4.5 RGT, B4.5S, B5.9 G, B5.9 GAS PLUS CM556, B5.9 LPG, B5.9 LPG PLUS CM556, B6.7 CM2350 B121B, B6.7 CM2350 B135B, B6.7 CM2350 B136C, B6.7 CM2350 B148B, B6.7 G CMOH6.0 B125, B6.7N CM2380 B150B, B6.7S, F3.8 CM2350 F120B, F3.8 CM2350 F128C, F3.8 CM2350 F132B, F3.8 F102, G3.9, G5.9, G5.9 CM558, ISB (CHRYSLER), ISB CM2150, ISB CM2150 E, ISB CM550, ISB CM850, ISB/ISD4.5 CM2150 B119, ISB/ISD4.5 CM2150 SN, ISB/ISD6.7 CM2150 B120, ISB/ISD6.7 CM2150 SN, ISB/ISD6.7 CM2880 B126, ISB3.9 CM2220 B107, ISB4.5 CM2150, ISB5.9G CM2180, ISB6.7 2010 DCX PICKUP, ISB6.7 2013 DCX CHASSIS CAB, ISB6.7 CM2150 SQ, ISB6.7 CM2250, ISB6.7 CM2350 B101, ISB6.7 CM2350 B103, ISB6.7 CM2350 B142, ISB6.7 CM2670 B153B, ISB6.7 G CM2180 B118, ISBE CM2150, ISBE CM800, ISBE2/ISBE3 CM850, ISBE4 CM850, ISD4.5 CM2150, ISD6.7 CM2880 D101, ISF2.8 CM2220, ISF2.8 CM2220 AN, ISF2.8 CM2220 EC, ISF2.8 CM2220 ECF2, ISF2.8 CM2220 F101, ISF2.8 CM2220 F117, ISF2.8 CM2220 F122, ISF2.8 CM2220 F126, ISF2.8 CM2220 F129, ISF2.8 CM2220 IAN, ISF3.8 CM2220, ISF3.8 CM2220 AN, ISF3.8 CM2220 F103, ISF3.8 CM2220 F110, ISF3.8 CM2220 F116, ISF3.8 CM2220 F134B, ISF3.8 CM2220 IAN, ISF3.8 CM2350 F109, ISF4.5 CM2220 F123, ISG11 CM2880 G106, ISG11 CM2880 G108, ISG12 CM2880 G107, ISG12 CM2880 G109, ISG12 G CMOH6.0 G111, QSB3.9 30 CM550, QSB3.9 CM2880 B138, QSB4.5 30 CM550, QSB4.5 CM2150 B108, QSB4.5 CM2250 B131, QSB4.5 CM2250 EC, QSB4.5 CM2350 B106, QSB4.5 CM2350 B122			



SMALL | MEDIUM | LARGE

Cart	Ref No	Part Number	Part Description	Required	Remarks
<input type="button" value="View My Cart"/>					
		AH9051-01	Air Intake Heater		Me-grid Air Heater...(More)
					Engine Family: B Series
					Component Provided: Heater
					Heater Voltage: 12
					Heater Amperage: 190
					Minimum Alternator Amperage:
					TBD
					Controls Provided: No
					Heater/Spacer Bolt Pattern

					(mm): 75x320
					Unique Characteristics: 1/2
					Inch CI Connection at Rear
					of Heater
					Engine Design Phase: Current
					Product
					Engine Aspiration: Jacket
					Water Aftercooled
					Terminal Orientation: 6
					Cylinder - Rear Mounting
					location for WARNING label
					For Turbocharged and Charge
					Air Cooled engines, the
					warning label to be attached
					to the outboard side of the
					heater.
					For Jacket Water Aftercooled
					engines the warning label to
					be attached to the outboard
					side of the aftercooler.
					DEP will omit 3927335 tag
					instruction from
					U.K. option to comply with
					European legislation.
					Studded capscrew 3920344 on
					#5 cylinder valve cover.
					Mounting location for ground
					wire is on stud on #5 valve
					cover.
<input type="checkbox"/>	1	3900240	Regular Hexagon Nut	1	M8 X 1.25.

<input type="checkbox"/>	2	3900589	Hexagon Flange Nut	1	M8 X 1.25
<input type="checkbox"/>	3	3900629	Hexagon Flange Head Cap Screw	1	M8 X 1.25 X 16
<input type="checkbox"/>	4	3913638	Hexagon Flange Head Cap Screw	1	M6 X 1.00 X 16.
<input type="checkbox"/>	5	3920344	Studded Flange Cap Screw	1	M8 X 1.25 X 21
<input type="checkbox"/>	6	3927335	Instruction Tag	1	
<input type="checkbox"/>	7	3008468	Pipe Plug	1	1/2 NPT.
	8	3928517	Intake Air Heater	1	
<input type="checkbox"/>	9	3928702	Ground Wire	1	
<input type="checkbox"/>	10	3931347	Intake Manifold Cover Gasket	1	

© 2019 Cummins Inc., Box 3005, Columbus, IN 47202-3005 U.S.A.
Terms of Use and Disclaimers | Recommended System Requirements
Need Assistance? Please click on the Contact Us button in the top right corner of any page.